

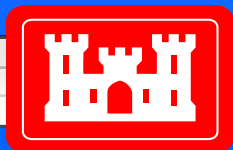

Borrego Maneuver Area
TPP-3
May 24th 2006



Los Angeles District





TPP2 Meeting Recap

- Held on 15 February 2006
- Approximately 35 in attendance
- Presentations provided:
 - FUDs and LA Corps MMRP overview
 - BMA RI/FS schedule
 - Public Involvement Plan overview
 - Naming Rationale for MRA/MRSs
 - BMA Conceptual Site Model (CSM) overview
 - Remedial Investigation Objectives
 - Field Investigation Methods
 - Stakeholder Working Group

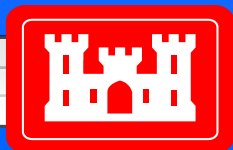

Los Angeles District





BMA Munitions Response Areas

MRA-1101 Mechanized
Artillery Range

MRA-1102 Camp Ensign

MRA-1103 Clark Dry Lake

MRA-1104 Borrego Hotel

MRA-1105 Military Wash

MRA-1106 Benson/Ocotillo
Dry Lake

MRA-6700 Winona Bombing
Target 1 (# 90)

MRA-6800 Winona Bombing
Target 2 (# 91)

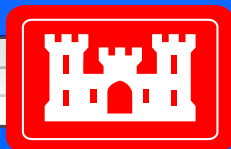
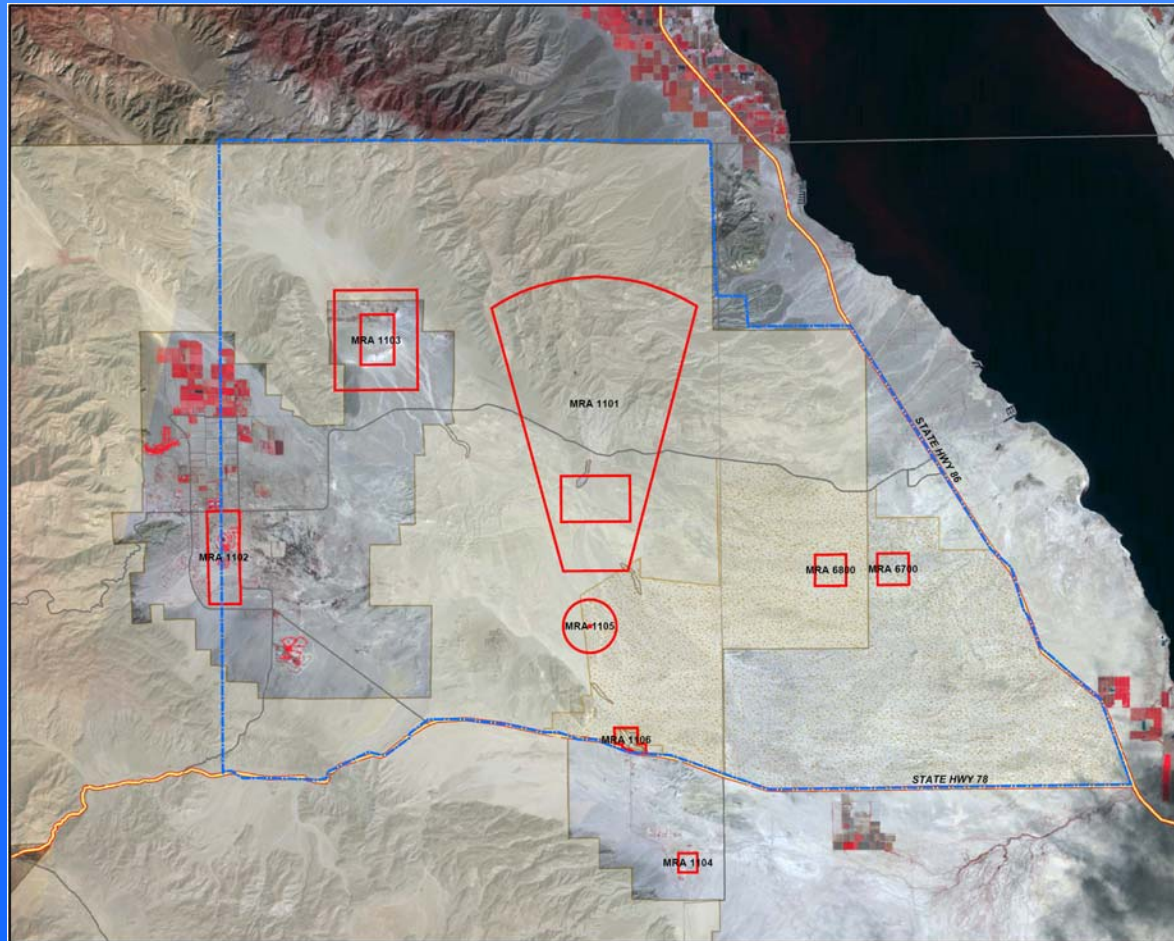

Los Angeles District





Technical Approach Review

Technology Evaluation (GPO)
Investigation Planning
Surface Visual Survey
Geophysical Investigation
Reacquisition and Intrusive Investigation
MEC Demilitarization and Disposal
MC Sampling
Reporting

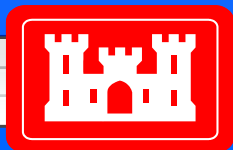

Los Angeles District





Technology Evaluation (GPO)

- GPO Evaluation
 - Evaluate proposed geophysical equipment for site investigation
 - Determine most probable munitions
 - Determine penetration and detection depths
 - Select representative location
 - Optimize geometry, configuration and acquisition parameters for selected equipment

- Site-Specific DGM evaluation
 - Test strip with end member most probable munitions
 - Daily QC evaluation
 - Daily Evaluation of instrument response

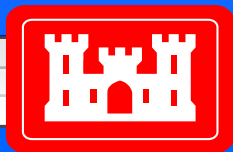
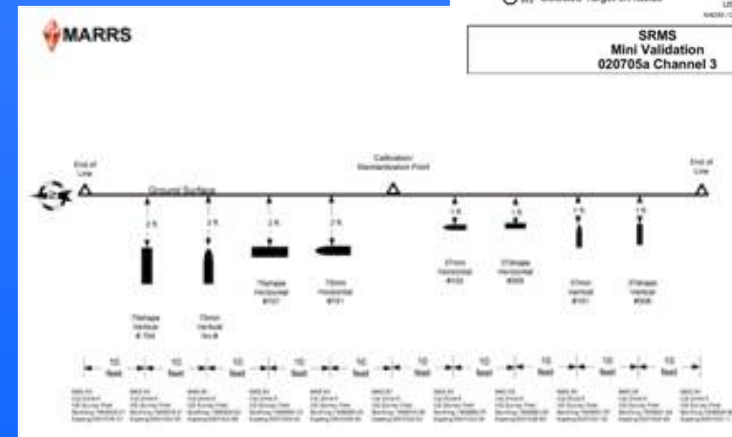
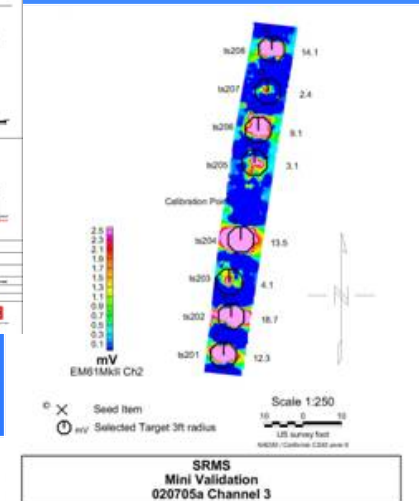
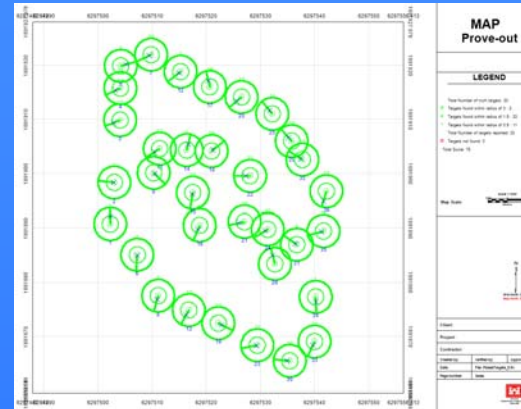

Los Angeles District





Surface Visual Survey

- Sweep line with personnel spaced appropriate to conditions
- Detector aided surface surveys assist in areas where vegetation or geologic conditions obscure visual recognition
- Surface Visual Survey results will determine the size and number of MRS units within each MRA

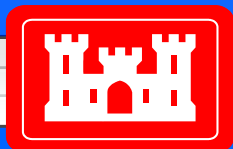

Los Angeles District





Geophysical Investigation

MRA Investigation Mapping

- MRA Geophysical Investigation coverage is determined by the total area of the site
- Survey coverage based on recommended minimum coverage as stated in EM 1110-01-4009
- Coverage requirements were selected from the most conservative models considering the total survey area and target dimensions



MRS Delineation Mapping

- MRS Geophysical Investigation area is determined by the observed distribution of munitions debris and/or the munitions with the greatest fragmentation distance (MGFD)

Engineering Manual EM 1110-01-4009 Guidelines

Sector Size, Acres	Sector Size, Hectares	Required Minimum Area Investigated	Recommended Minimum Area Investigated
<50	<20.2	5.00%	7.50%
51 - 100	20.6 - 40.5	3.00%	4.50%
101 - 150	40.9 - 60.7	2.00%	3.00%
151 - 1000	61.1 - 404.7	1.00%	1.50%
>1000	>404.7	0.50%	0.75%

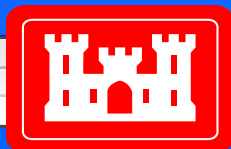

Los Angeles District





Target Selection and Investigation

- DGM Data Analysis
 - DGM Results recorded into the target data base
 - DGM Targets are then prioritized based on target characteristics
- Target Investigation
 - Reacquisition is performed by UXO Technicians using survey grade GPS and real-time detectors
 - Intrusive operations conducted manually using UXO avoidance techniques

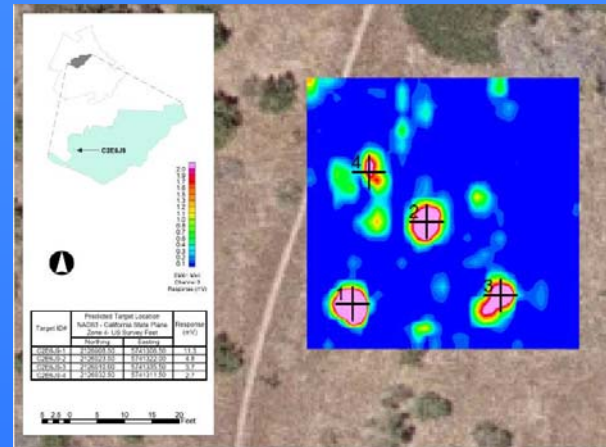

Los Angeles District





Natural and Cultural Resources

- Work in concert with industry professionals to develop site procedures
- Develop site specific training to minimize impact of project practices
- Utilize Site Monitors and Resource Specialists as required for intrusive activities
- Employ avoidance practices wherever possible to minimize site disturbance

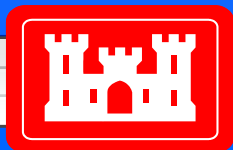

Los Angeles District





MEC Demilitarization and Disposal

- Identification
- Disposition
 - Storage
 - Demolition
- Reporting

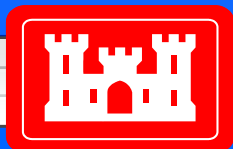

Los Angeles District





Soil Sampling for MC

MC samples will be taken in each MRS based on munitions concentration and visual cues such as soil staining

Sample locations will be added as additional MRSs are identified

Composite sampling

- Large areas of concern
- UXO Blow-in-place (BIP)

Analyses

- Explosives, EPA Test Method 8330
- Metals (if explosives), EPA Test Method 6020B (based on metals present in observed munitions)

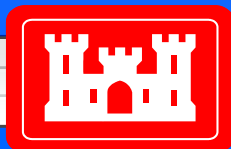
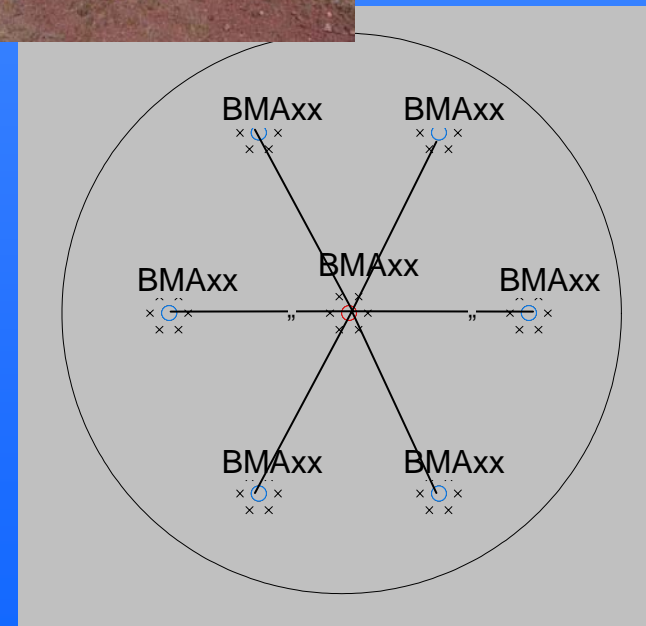

Los Angeles District





Remedial Investigation (RI) Objectives

Collect sufficient data to:

- Address ASR identified MRS locations
- Determine whether MRS(s) exist within each MRA
- If present, define boundaries of MRS(s) within each MRA
- Define the distribution and density of MEC within each MRS

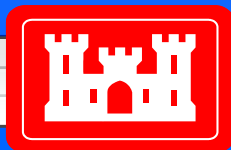

Los Angeles District





MRA Investigation Procedures

1. MRA investigation utilizing combined surface sweep team and DGM (survey spacing based on EM-1110-1-4009 and ASR defined Target/Training Activities)
2. MRA Data Analysis
3. MRA Intrusive Investigation
4. GIS Analysis of MRA results, ASR, and Stakeholder provided data to determine approximate location of MRS based on MD distribution
5. Build MRS buffer based on MD distribution and $\frac{1}{2}$ the ASR identified target diameter or the MGFID identified during the intrusive investigation
6. MRS Total Coverage Surface Visual Survey as determined by site conditions. (note a 1000ft by 1000ft MRS is a 23 acre investigation area.)
7. GIS Analysis of Visual Survey Data
8. MRS DGM Investigation with transect spacing based on based on EM 1110-1-4009.
9. MRS Data Analysis
10. MRS Intrusive Investigation
11. GIS Analysis of MRS results
12. Refine the MRS boundary for RI recommendations.
13. Repeat Steps 5 – 12 for each identified MRS

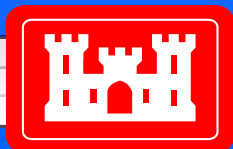

Los Angeles District





Integrated Investigation Plan

Determine the appropriate MRA transect spacing based on EM 1110-1-4009 and identified target/training activities

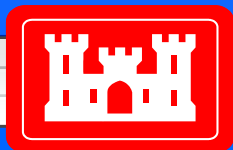
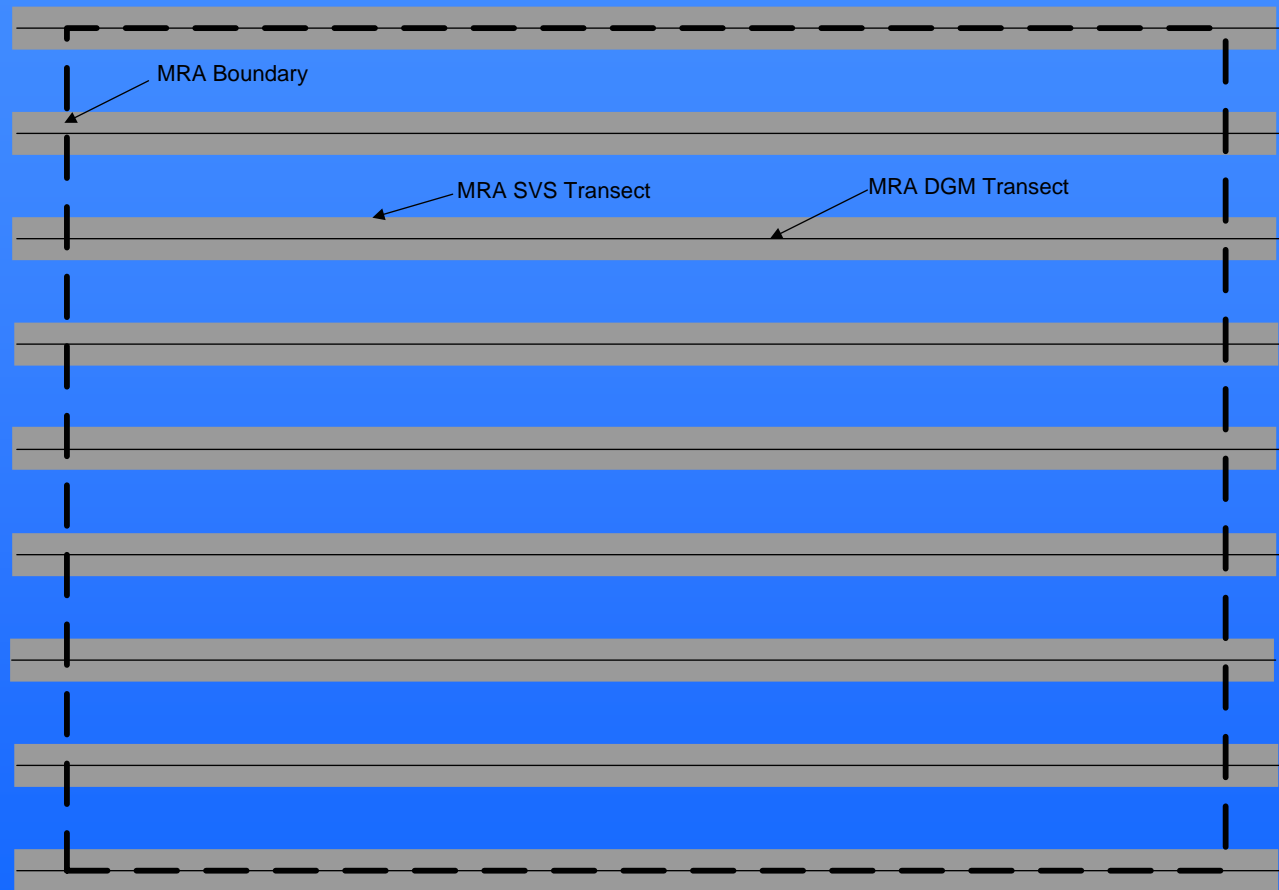

Los Angeles District





Integrated Investigation Plan

Post MRA
surface visual
survey and DGM
results to GIS to
identify and
locate potential
MRS boundaries

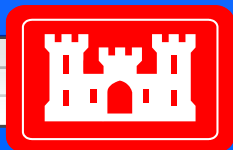
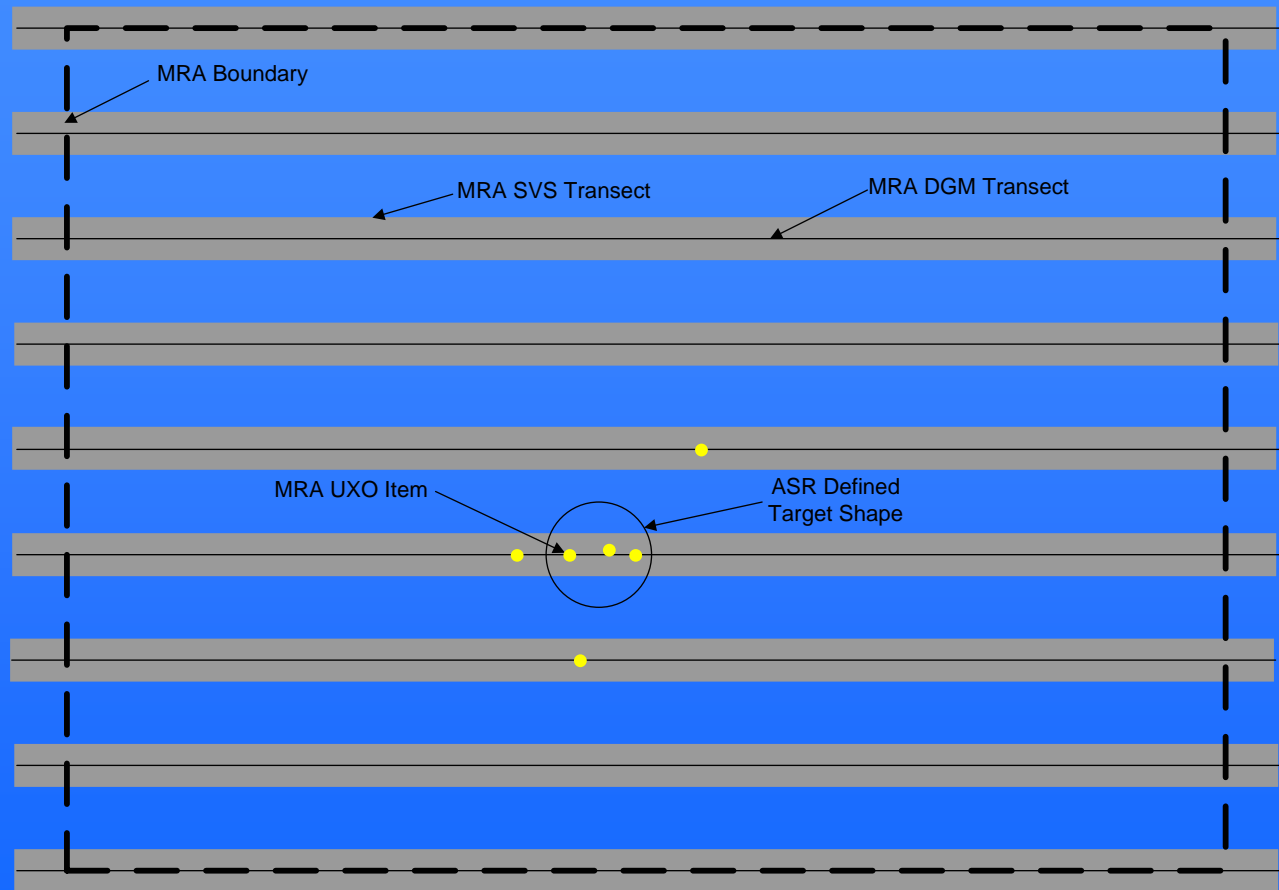

Los Angeles District





Integrated Investigation Plan

Plot MRS buffer and MRS DGM boundary and transects for total coverage surface visual survey and DGM investigation

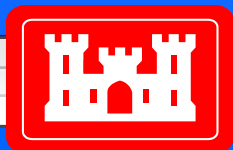
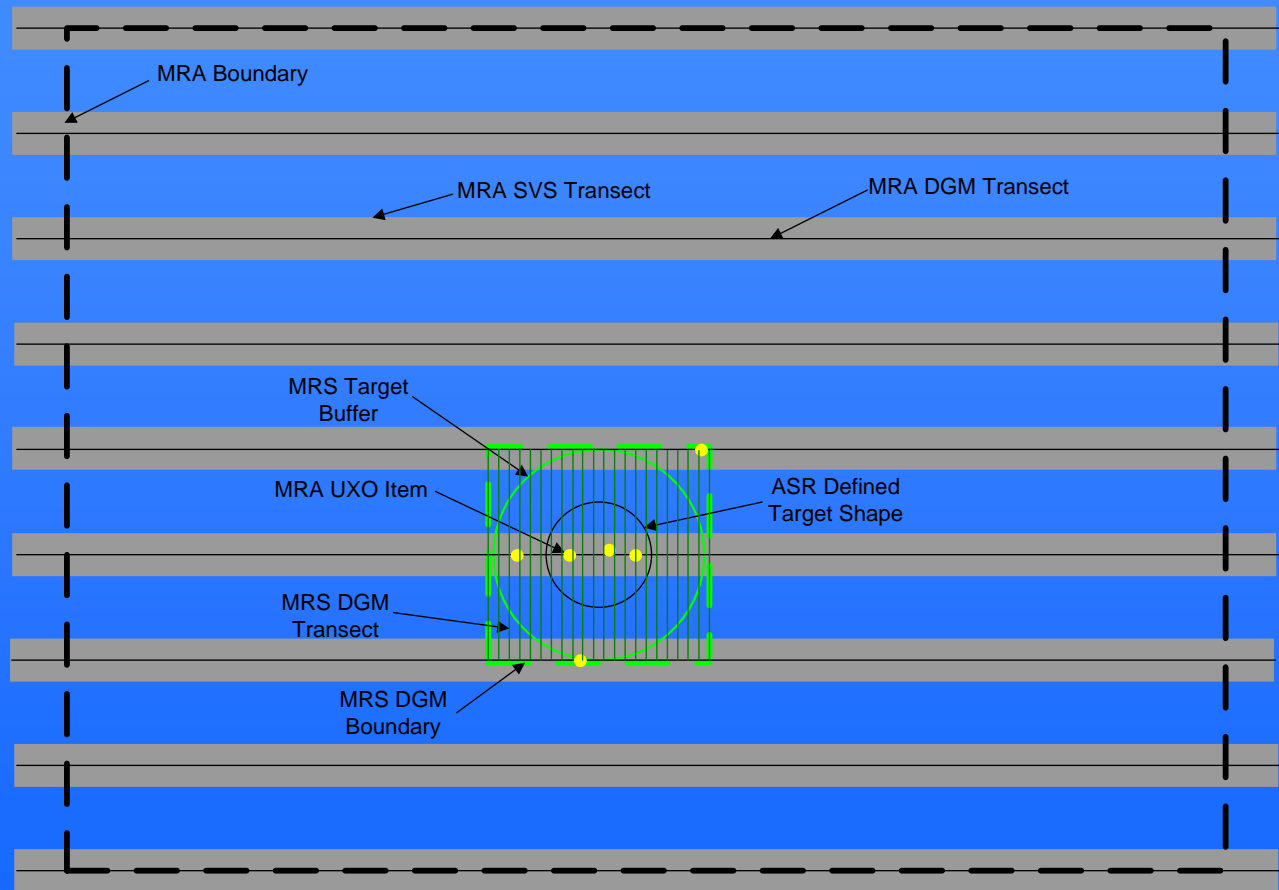

Los Angeles District





Integrated Investigation Plan

Post surface
visual survey
and DGM results
to GIS

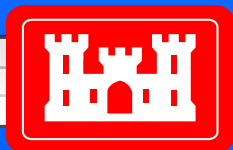
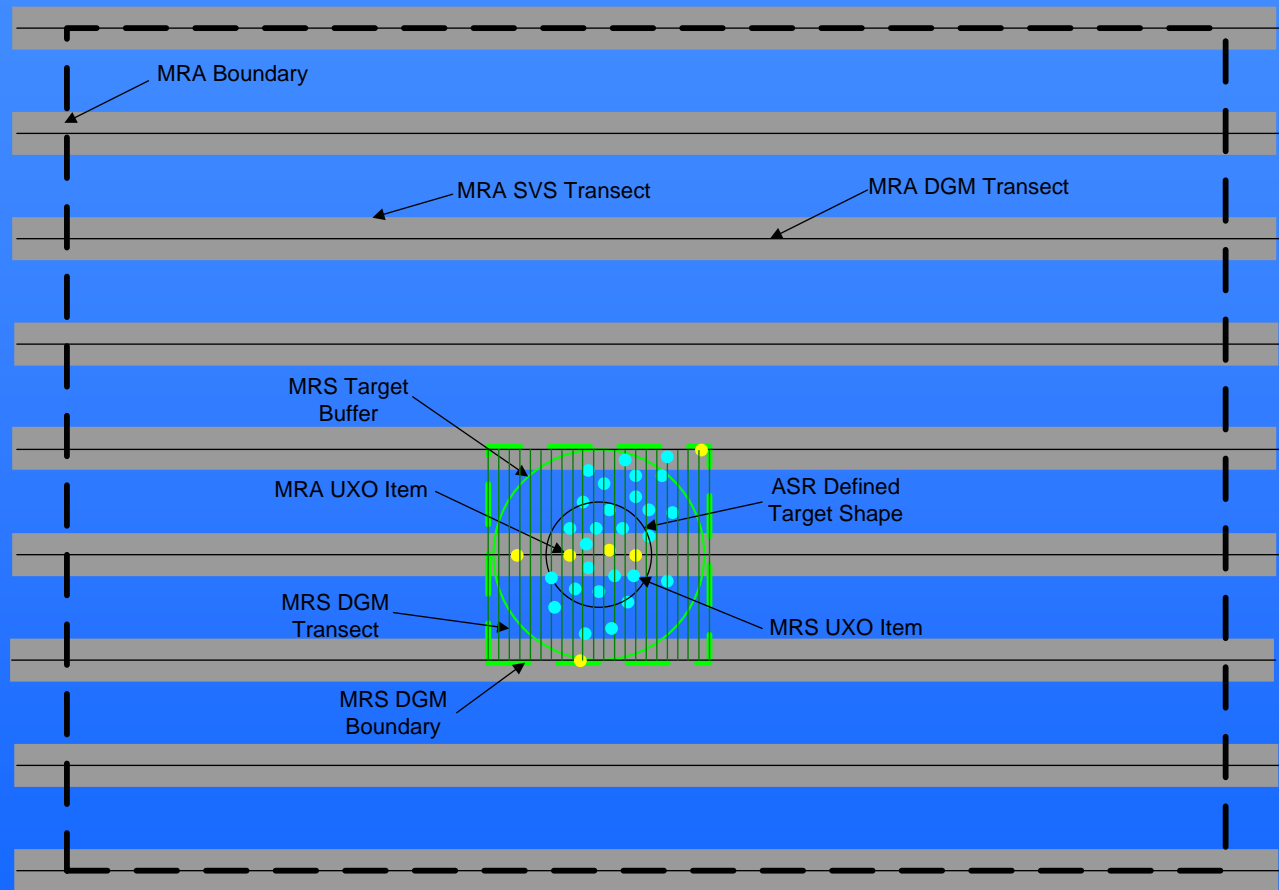

Los Angeles District





Integrated Investigation Plan

Refine the MRS boundary for RI recommendations

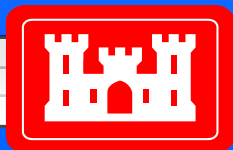
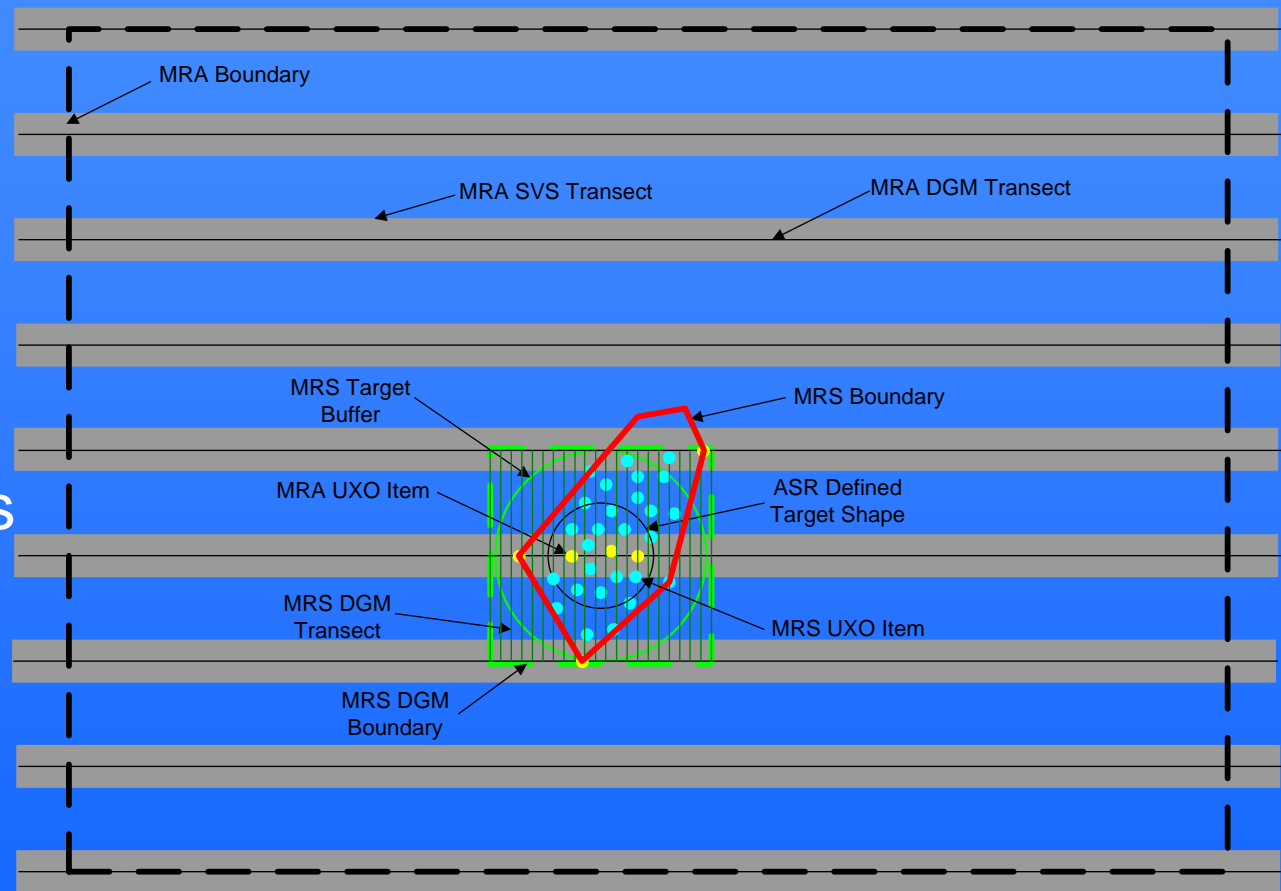

Los Angeles District





MRA-1101 Mechanized Artillery Range (A1) and Range Buffer (A2)

MRA Investigation

- Transect Based Surface Visual Survey and DGM
- Total Size = 10,496 hectares (ha) (25,937 acres [ac])
- 0.75% survey coverage, 30 ha (74 ac)
- Line coverage, 299 km (186 mi)
- Maximum transect spacing, 133 m (437 ft)
- Judgmental transect spacing, 133 m (437 ft)

MRS Investigation

- Total Coverage Surface Visual Survey
- Transect Based DGM
- Target Size, 344 m (1,095 ft) radius 40mm MGF
- MRS Area w/buffer, 35 ha (86 ac)
- 4.5% survey coverage, 1.6 ha (3.9 ac)
- Line coverage, 16 km (10 mi)
- Maximum transect spacing, 22 m (73 ft)
- Judgmental transect spacing, 20 m (66 ft)

MC Sampling: Based on MEC investigation Results

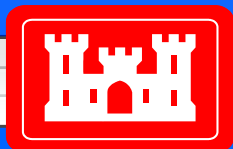
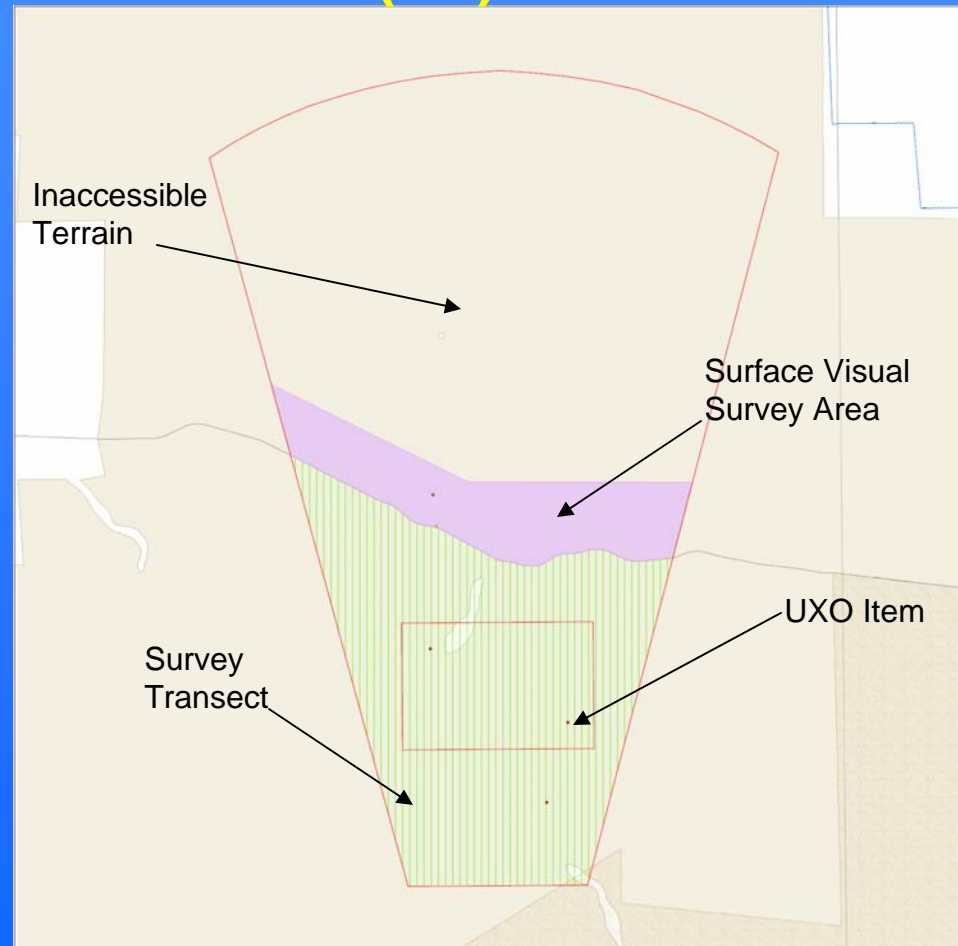

Los Angeles District





MRA-1102 Camp Ensign

- Surface Visual Survey: 100% visual coverage

MRS Investigation

- Size = NA
 - Survey coverage = NA
 - line coverage = NA
 - transect spacing = NA
- MRA Investigation
 - Transect Based Surface Visual Survey
 - Total Size = NA
 - Survey coverage = NA
 - line coverage = NA
 - transect spacing = NA
 - MC Sampling: Based on MEC investigation results

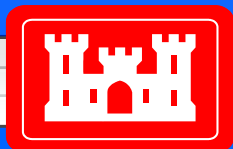
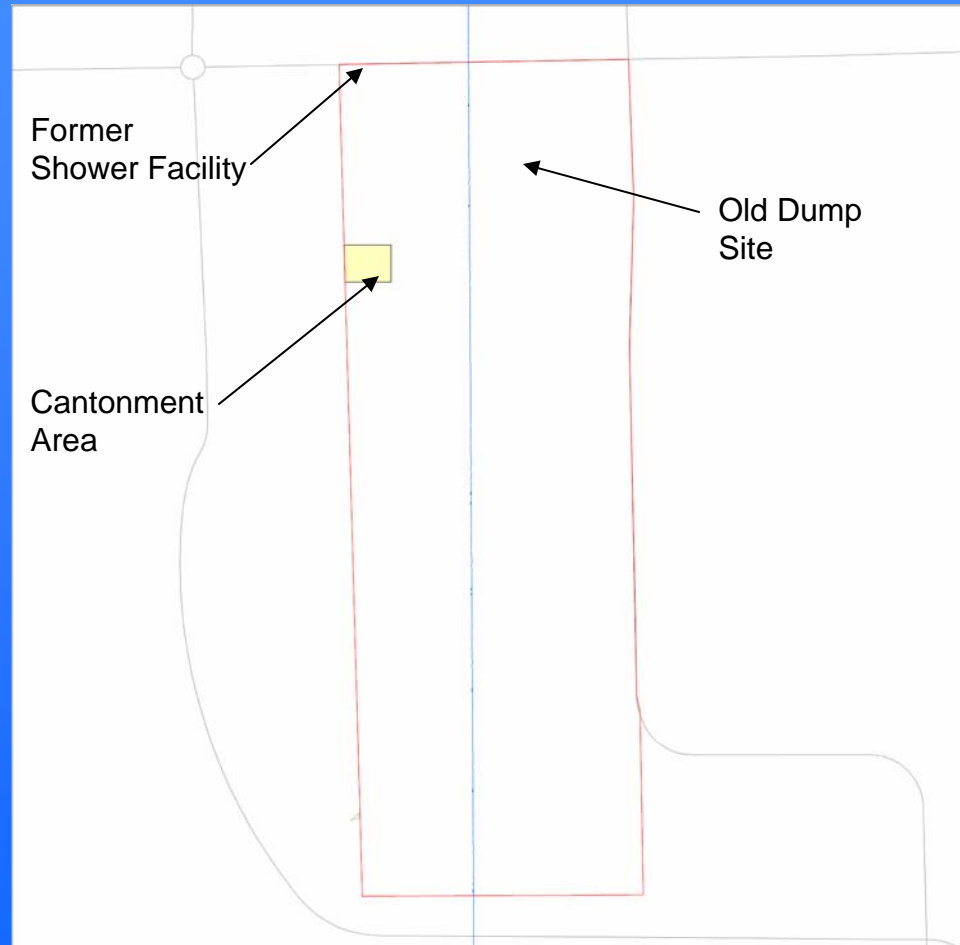

Los Angeles District





MRA-1103

Clark Dry Lake (E1 / E2 North)

MRA Investigation

- Transect based Surface Visual Survey and DGM
- Total Size, 2,259 hectares (ha) (5,580 acres [ac])
- 0.75% survey coverage, 17 ha (42 ac)
- Line coverage, 170 km (106 mi)
- Maximum transect spacing, 133 m (437 ft)
- Judgmental transect spacing, 100 m (328 ft)

MRS Investigation

- Total Coverage Surface Visual Survey
- Transect Based DGM
- Target Size = 150 m (500 ft) diameter bomb target
- MRS Area w/buffer, 9.3 ha (23 ac)
- 7.5% survey coverage w/buffer, 0.70 ha (1.7 ac)
- Line coverage, 7.0 km (4.3 mi),
- Maximum transect spacing, 13 m (44 ft)
- Judgmental transect spacing, 12 m (40 ft)

MC Sampling: Based on MEC investigation Results

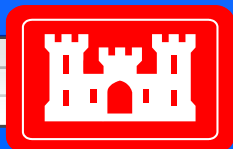
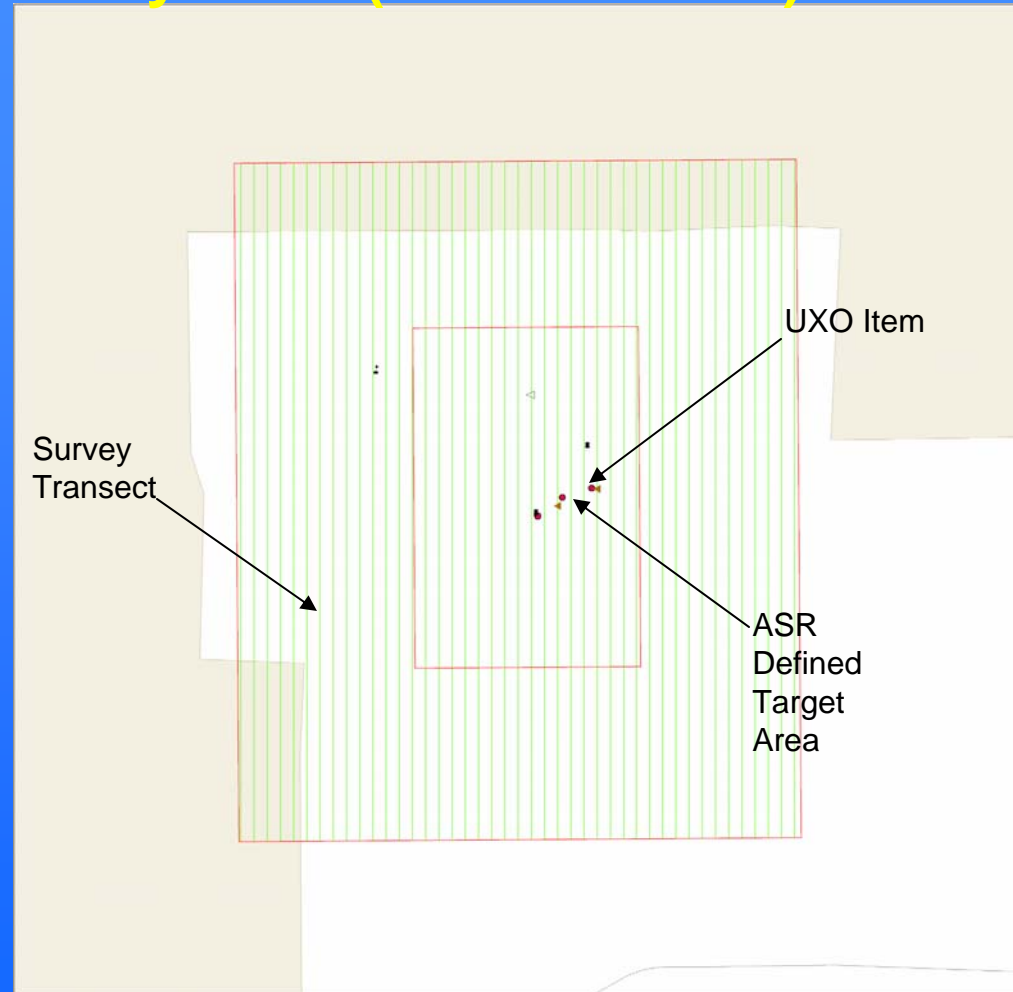

Los Angeles District





MRA-1104 Borrego Hotel

MRA Investigation

- Transect based Surface Visual Survey and DGM
- Total Size, 90 hectares (ha) (222 acres [ac])
- 1.5% survey coverage, 1.3 ha (3.3 ac)
- Line coverage, 13 km (8 mi)
- Maximum transect spacing, 67 m (219 ft)
- Judgmental transect spacing, 60 m (197 ft)

MRS Investigation

- Total Coverage Surface Visual Survey
- Transect Based DGM
- Target Size = 150 m (500 ft) diameter bomb target
- MRS Area w/buffer, 9.3 ha (23 ac)
- 7.5% survey coverage w/buffer, 0.70 ha (1.7 ac)
- Line coverage, 7.0 km (4.3 mi),
- Maximum transect spacing, 13 m (44 ft)
- Judgmental transect spacing, 12 m (40 ft)

MC Sampling: Based on MEC investigation Results

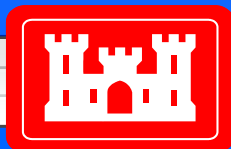
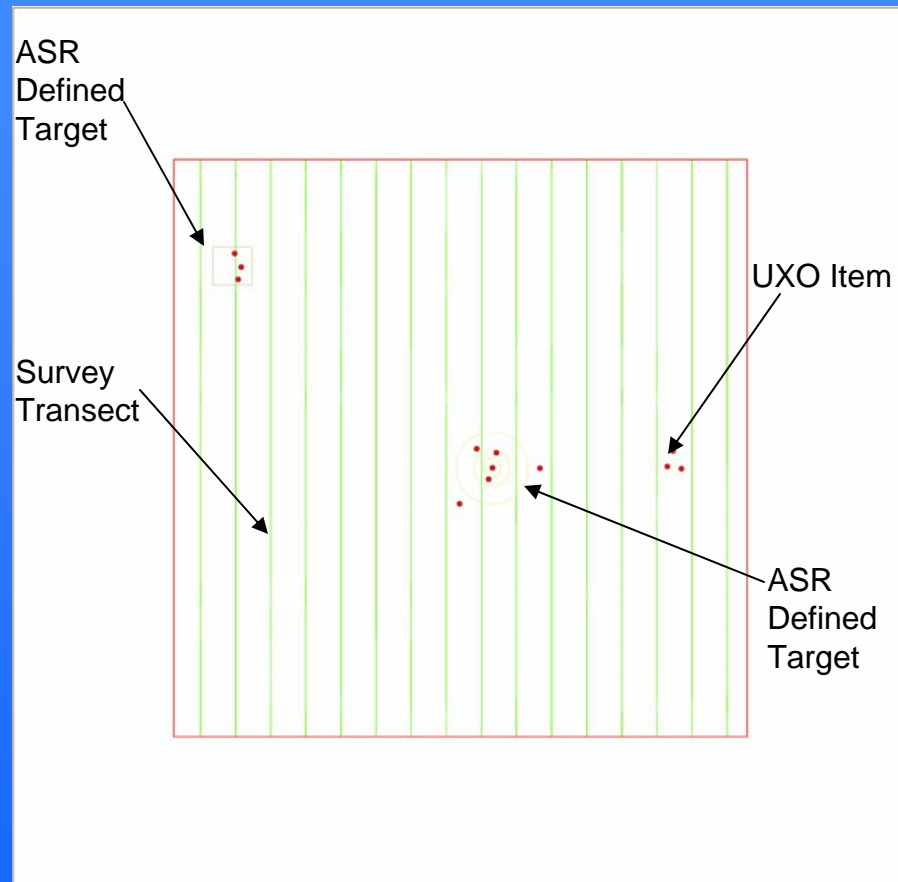

Los Angeles District





MRA-1105 Military Wash (E1 / E2)

MRA Investigation

- Transect based Surface Visual Survey and DGM
- Total Size, 591 hectares (ha) (1,460 acres [ac])
- 0.75% survey coverage, 4.4 ha (11 ac)
- Line coverage, 44 km (27.5 mi)
- Maximum transect spacing, 133 m (437 ft)
- Judgmental transect spacing, 75 m (246 ft)

MRS Investigation

- Total Coverage Surface Visual Survey
- Transect Based DGM
- Target Size = 150 m (500 ft) diameter bomb target
- MRS Area w/buffer, 9.3 ha (23 ac)
- 7.5% survey coverage w/buffer, 0.70 ha (1.7 ac)
- Line coverage, 7.0 km (4.3 mi),
- Maximum transect spacing, 13 m (44 ft)
- Judgmental transect spacing, 12 m (40 ft)

MC Sampling: Based on MEC investigation Results

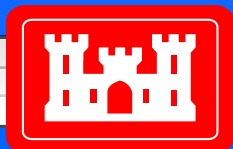
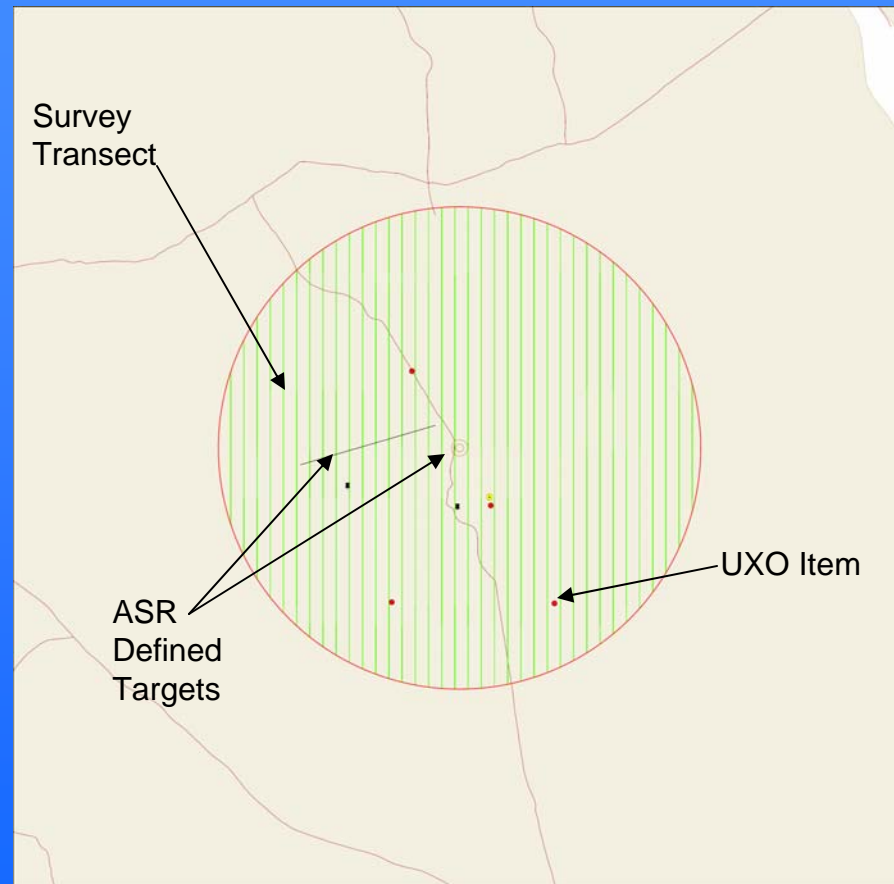

Los Angeles District





MRA-1106

Benson/Ocotillo Dry Lake

MRA Investigation

- Transect based Surface Visual Survey and DGM
- Total Size, 143 hectares (ha) (353 acres [ac])
- 1.5% survey coverage, 2.1 ha (5.2 ac)
- Line coverage, 21 km (13 mi)
- Maximum transect spacing, 67 m (219 ft)
- Judgmental transect spacing, 60 m (197 ft)

MRS Investigation

- Total Coverage Surface Visual Survey
- Transect Based DGM
- Target Size = 150 m (500 ft) diameter bomb target
- MRS Area w/buffer, 9.3 ha (23 ac)
- 7.5% survey coverage w/buffer, 0.70 ha (1.7 ac)
- Line coverage, 7.0 km (4.3 mi),
- Maximum transect spacing, 13 m (44 ft)
- Judgmental transect spacing, 12 m (40 ft)

MC Sampling: Based on MEC investigation Results

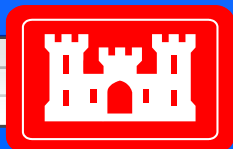
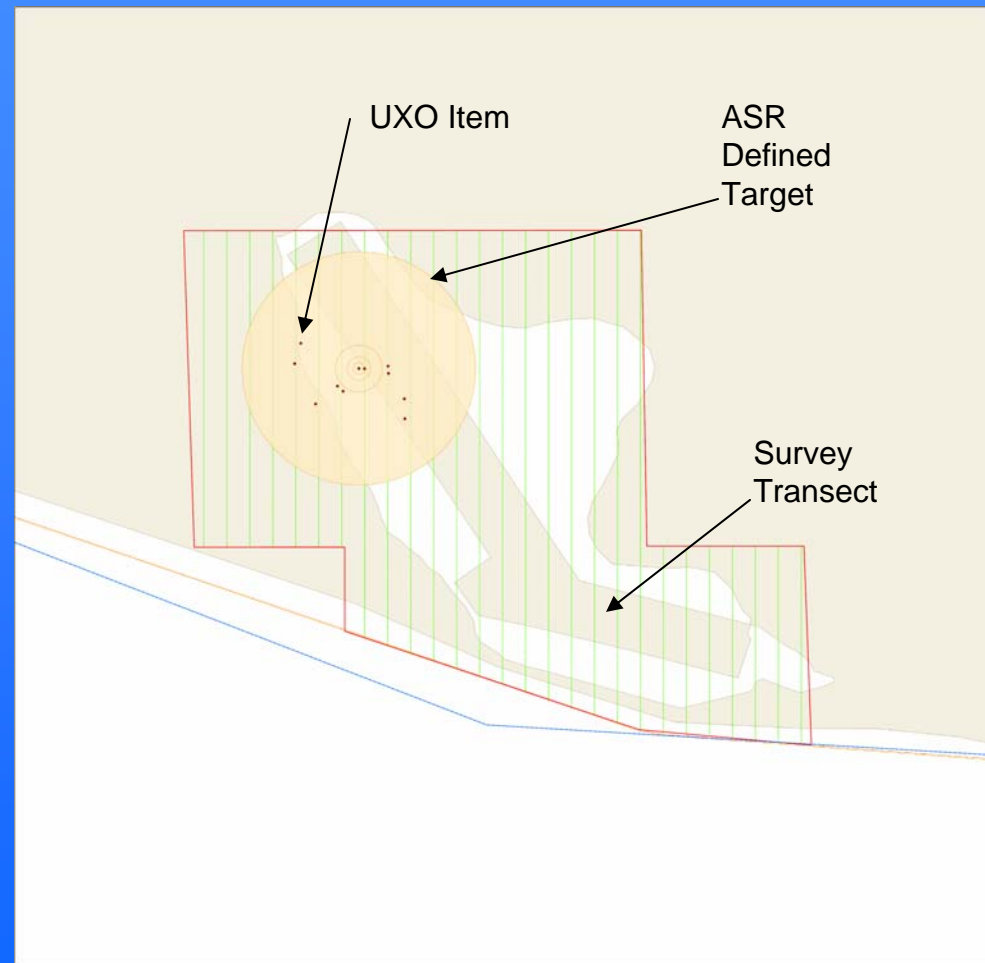

Los Angeles District





MRA-6700 Winona BT1, #90

MRA Investigation

- Transect based Surface Visual Survey and DGM
- Total Size, 259 hectares (ha) (640 acres [ac])
- 1.5% survey coverage, 3.9 ha (9.5 ac)
- Line coverage, 39 km (24 mi)
- Maximum transect spacing, 67 m (219 ft)
- Judgmental transect spacing, 60 m (197 ft)

MRS Investigation

- Total Coverage Surface Visual Survey
- Transect Based DGM
- Target Size = 150 m (500 ft) diameter bomb target (assumed similar to other targets)
- MRS Area w/buffer, 9.3 ha (23 ac)
- 7.5% survey coverage w/buffer, 0.70 ha (1.7 ac)
- Line coverage, 7.0 km (4.3 mi),
- Maximum transect spacing, 13 m (44 ft)
- Judgmental transect spacing, 12 m (40 ft)

MC Sampling: Based on MEC investigation
Results

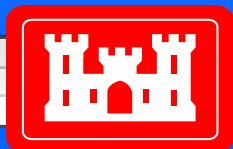
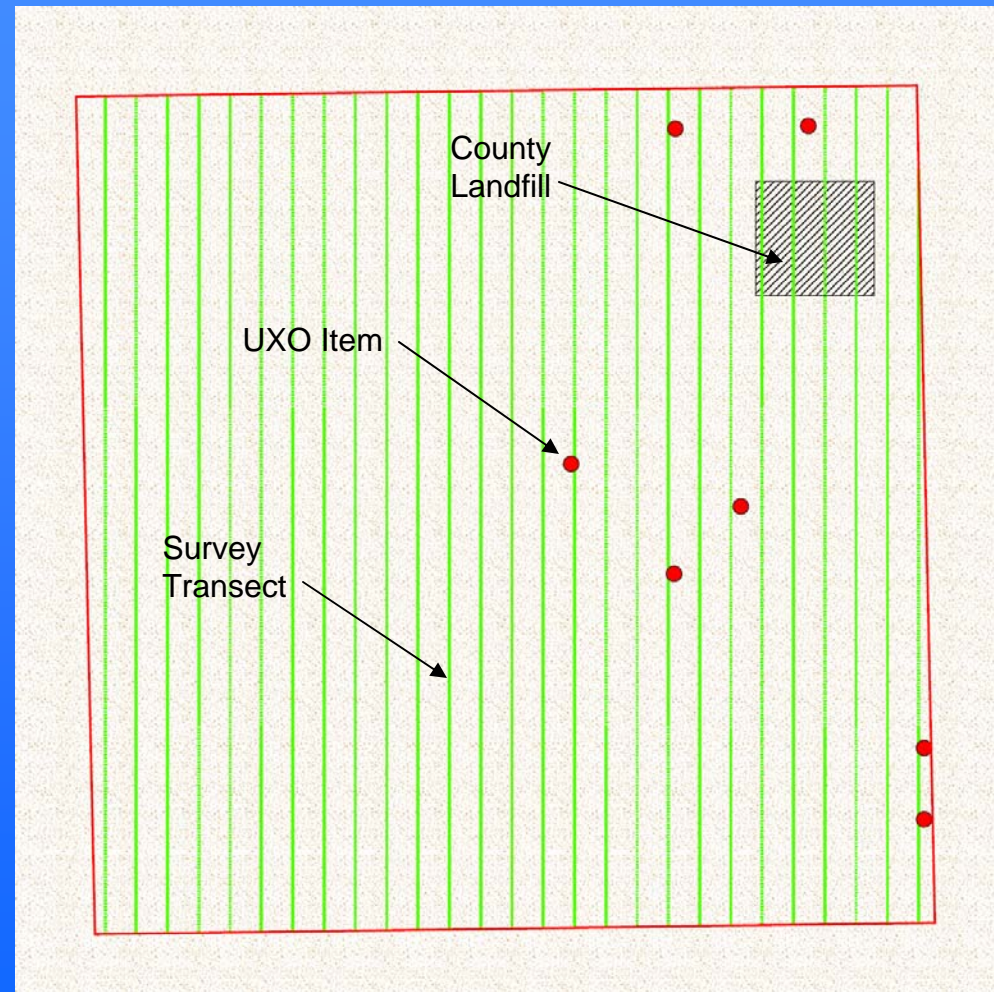

Los Angeles District





MRA-6800 Winona BT 2, #91

MRA Investigation

- Transect based Surface Visual Survey and DGM
- Total Size, 259 hectares (ha) (640 acres [ac])
- 1.5% survey coverage, 3.9 ha (9.5 ac)
- Line coverage, 39 km (24 mi)
- Maximum transect spacing, 67 m (219 ft)
- Judgmental transect spacing, 60 m (197 ft)

MRS Investigation

- Total Coverage Surface Visual Survey
- Transect Based DGM
- Target Size = 150 m (500 ft) diameter bomb target (assumed similar to other targets)
- MRS Area w/buffer, 9.3 ha (23 ac)
- 7.5% survey coverage w/buffer, 0.70 ha (1.7 ac)
- Line coverage, 7.0 km (4.3 mi),
- Maximum transect spacing, 13 m (44 ft)
- Judgmental transect spacing, 12 m (40 ft)

MC Sampling: Based on MEC investigation
Results

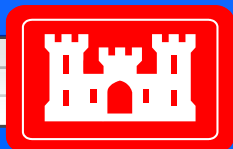
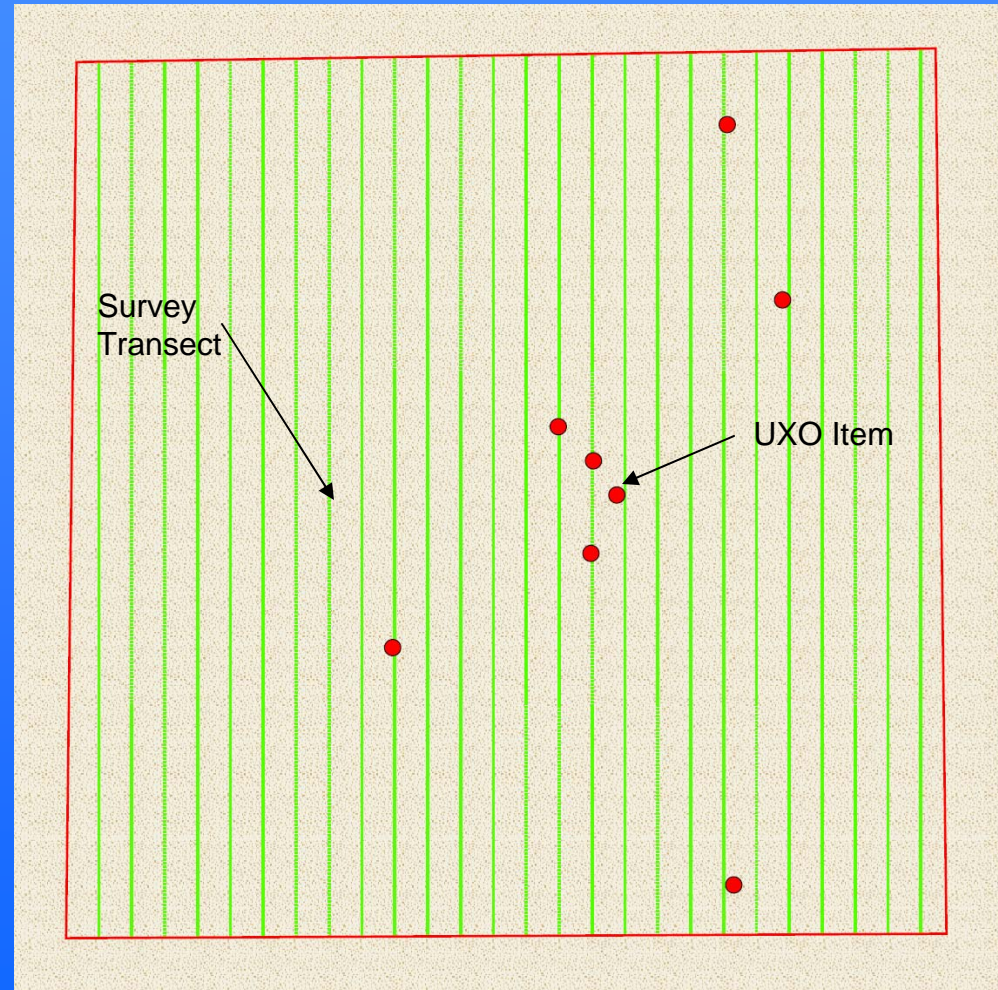

Los Angeles District





BMA RI/FS Workplan

Release of the Draft Workplan will be announced to all Stakeholders via email.

Draft Final BMA RI/FS Workplan will be available for viewing and download

- The Borrego Springs Public Library
- BMA Project Website: <http://www.borregosprings-mmrp.org/>
- TPP3 CD

Comments will be directed to

- Larry Sievers, FUDS Program Manager
 - Email larry.a.sievers@usace.army.mil

Or

Mail to USACE,
915 Wilshire Blvd, Ste. 15011
Los Angeles, CA 90015
c/o Larry Sievers, BMA

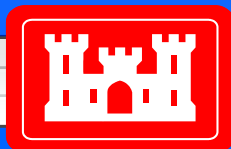

Los Angeles District





Thank You for Your Participation

- Thank You For Your Input
 - Next TPP August 8th 2006
 - Final RI Work Plan will be reviewed at the next TPP
 - Public Meeting this evening at 6 PM
-
- For more information visit the BMA website at www.borregosprings-mmrp.org

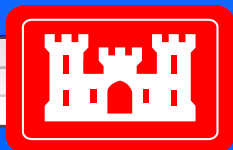

Los Angeles District

